

# JF-90

# 筒子纱高效脱水机

## JF-90 High Efficient Yarn Package Hydroextractor



### JF-90 系列筒子纱高效脱水机

◆ JF-90型高效脱水机，适用于筒子纱染色后的脱水工序，适用全棉、化纤、羊绒线、各种化纤纱线、筒子纱的脱水。

#### JF-90高效脱水机特点

- ①转速1530转/分钟，纯棉脱水后含水率45%，提高了生产效率，为下道工序烘干节省了成本。
- ②脱水后含水量一致，确保纱线在烘干前的均匀回潮率。
- ③每个筒子纱有单独固定的支撑架，不会在脱水时损坏纱线及染色管。
- ④变频调速及平稳升速降速。
- ⑤PLC全自动控制系统，开机后可自动循环工作。
- ⑥独特的平衡避震设计，及平衡保护装置，确保运转安全、平衡。

#### 标准配置

- ①2个脱水转筒悬挂式马达驱动及避震平衡装置。
- ②4个旋转式纱架。
- ③油压式升、降纱架系统及配套油泵。
- ④PLC全自动控制系统配不锈钢控制柜。
- ⑤铸铁底座及升降立柱。

### JF-90 high efficiency package hydroextractor

◆The JF-90 model high efficiency hydroextractor is a semiautomatic centrifugal extractor suitable to eliminate the excess of water from all types of yarn packages after dyeing. It can be successfully used for synthetic, artificial and natural yarns wound on plastic cones / tubes or stainless steel springs.

#### Special features of the JF-90 hydroextractor

- ◆The high rotation speed (1530rpm) ensures a very low and uniformly distributed residual moisture content in the yarn packages (e.g. down to 45% on some cotton yarns) which ensures even moisture regain rate for yarn before drying, thus reducing the overall drying cost and improving the final product quality.
- ◆The water content is the same after hydroextraction, to ensure even moisture regain of yarn before drying.
- ◆Each package is put onto a separate holder to prevent yarn as well as cones / tubes from damages during the hydroextraction cycle.
- ◆The rotation speed is adjusted by means of an inverter, which ensures smooth speed increase / decrease.
- ◆The control system by PLC ensures the fully automatic operation of the machine until the end of each hydroextraction cycle, when the yarn has reached the designed final moisture content.
- ◆The unique anti-vibration design ensures smooth rotation of the baskets without unbalancing and the overall stable operation of the machine.

#### Standard configuration

- ◆2 suspended-type extracting baskets in stainless steel with individual driving motors and balancing devices.
- ◆4 rotating package holders with individual arms.
- ◆Hydraulic lifting / lowering system of the package holders equipped with oil pump.
- ◆Fully automatic control system by PLC housed inside the stainless steel control box.
- ◆Cast iron base plate with upper and lower column.



### 技术参数:

类别	脱水时间	剩余水份
晴纶化纤纱	3分钟	8-12%
毛混纺纱	4分钟	15-25%
毛纱	4分钟	25-30%
全棉纱	5分钟	45-50%
蚕丝	5分钟	35-40%
粘胶纤维	5分钟	60-70%

### Production Data:

Yarn type	Extraction time	Residual moisture
Synthetics	3min	8-12%
Wool blends	4min	15-25%
Wool /cotton blends	4min	25-30%
Cotton	5min	45-50%
Silk	5min	35-40%
viscose	5min	60-70%

### 规格:

类别	型号	JF-90
生产能力		480个纱/小时
功率		16kw
转速		1530转/分钟
自身重量		3200公斤
外形尺寸		2600X2210X2620毫米

### Specifications:

Spec.	Model	JF-90
Average capacity		480packages/h
Installed power		16kw
Rotation speed		1530rpm
Net weight		3200kg
Dimensions		2600X2210X2620mm

备注: 以筒子纱最大外径φ200毫米计算

Note : based on max package diameter 200 mm

### 平面图 Drawing

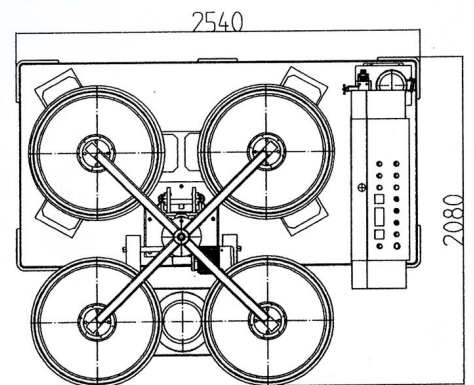
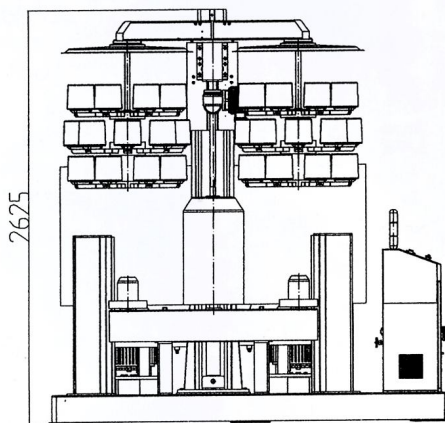
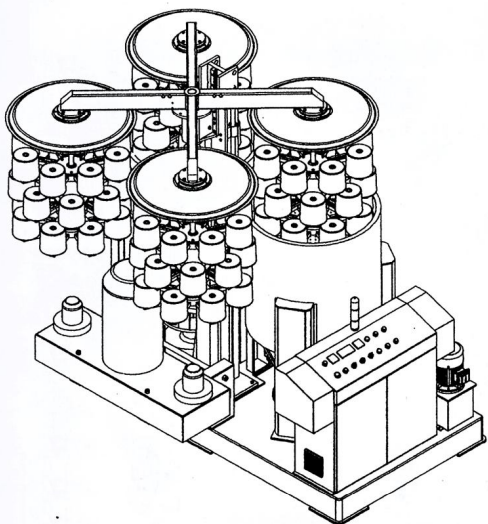

## WUXI SUNSKY MACHINERY CO.,LTD

Add: Youlian industrial Zone, Qianzhou Town, Huishan district, Wuxi, Jiangsu, China.

M: 0086-139 6872 6171 E-mail: info@sunsky-machine.com Http: //www.sunsky-machine.com